



Product Data Sheet:

830030-xx-xx

Advantage^{Li} Control Panel, Dual Release, Dual Detection, Dual Battery

Fixed and Mobile Energy Storage, Industrial, Commercial, and other installations



(830030 shown)

FEATURES:

- Dual Lithium Battery Powered, Standalone
- Dual Actuation Zone Fire Suppression Capability
- Dual Detection Zones
- Capable of releasing up to six Stat-X[®] aerosol generators on each of two actuation zones
- Numerous detection/releasing logic options including Cross Zoning
- Power and Actuation zone disable toggle switches
- Minimum 1-year service life Lithium Thionyl Chloride Batteries
- Two Class B Detection Circuits and one dedicated Class B Manual Release Circuit input
- Agent Cylinder Pressure Switch input
- Initiating Circuit and Pressure Switch Ground Fault indication
- Provides dedicated interface to supervised auxiliary remote fire alarm control panel for Fire and Trouble indication
- Windows based optional programming software
- Event logging and recording
- Three separately programmable optically isolated auxiliary contacts

- Interfaces to Multi Relay high current Auxiliary Switching Modules
- Includes rugged, sealed high temperature end of line devices
- Local Piezo Audible Alarm
- Audible Alarm Silence function
- Trouble indication LED and Annunciation
- Push to Test function
- Latching Alarm Reset
- Keyed Locking Access Door
- RoHS compliant construction
- Control Panel Thermal Environment Monitor

BENEFITS:

- Provides 24/7/365 Fire Detection and Actuation capability for Industrial installations
- Single and Dual Hazard zone Detection and Suppression
- Allows for Remote FACP Fire System initiating input
- Dual Lithium Primary and Secondary Batteries
- No external A/C power required
- Easy Installation & Maintenance
- Reduced installation and Maintenance Costs

PRODUCT DESCRIPTION:

The Advantage^{Li} Dual Release, Dual Battery Control Panel part no. 830030 is the latest result of years of rugged mining, transit, and military electronic control panel evolution. The Advantage^{Li} control panel uses Lithium Thionyl Chloride batteries which can operate for up to one year on the primary battery and includes an identical secondary backup battery as a UL required backup power source.

The Advantage^{Li} control panel can operate to protect single detection and single releasing hazard or can provide up to two separate detection and releasing zones. Two wire Class B supervision is provided for Detection, Manual Release and Agent Cylinder Pressure Switch zones. The Advantage^{Li} control panel can support spot thermal, linear thermal and relay base smoke detectors on each of two detection input zones. The Advantage^{Li} control panel can be remotely programmed for Detection and Releasing Zone mapping including cross zoning and auxiliary relay timing and operation. The Lithium Thionyl Chloride batteries are DOT approved for overnight shipping when not bulk packed.

Multiple auxiliary optically isolated relays provide up to 1 Amp switching capability and can interface to auxiliary relay modules for additional switching and logic functions. The auxiliary relay modules provide high current switching capability for solenoid operated gas valves, remote fans, etc. A dedicated set of FACP contacts are provided which allow supervision of the control panel by remote FACP's or other control devices. The Advantage^{Li} panel is constructed using RoHS compliant materials throughout.

A variety of detection input devices and remote annunciators are available. The Advantage^{Li} control panel may be directly mounted, recess or assembled to a DIN rail installation. Separate mounting bases are available.

Alternative wiring hub and manual release switch options are available. See product webpage for the latest configurations.

Part Numbering Matrix

Part No.	Part Description	Switch on Cover?	Wiring Hub Type
830030	Advantage-Lithium, Dual Det./Dual Rel., Metal Wiring Hubs, No Manual Release on Cover	No	½" Metal Conduit
830030-00-01	Advantage-Lithium, Dual Det./Dual Rel., Metal Wiring Hubs, Manual Release on Cover	Yes	½" Metal Conduit
830030-01-00	Advantage-Lithium, Dual Det./Dual Rel., Plastic Wiring Hubs, No Manual Release on Cover	No	½" Plastic
830030-02-01	Control Panel, Adv-Li, Dual Det./Dual Rel., No wiring hubs, with Manual Release	Yes	No



- Advantage^{Li} Control Panel Dimensional Data -

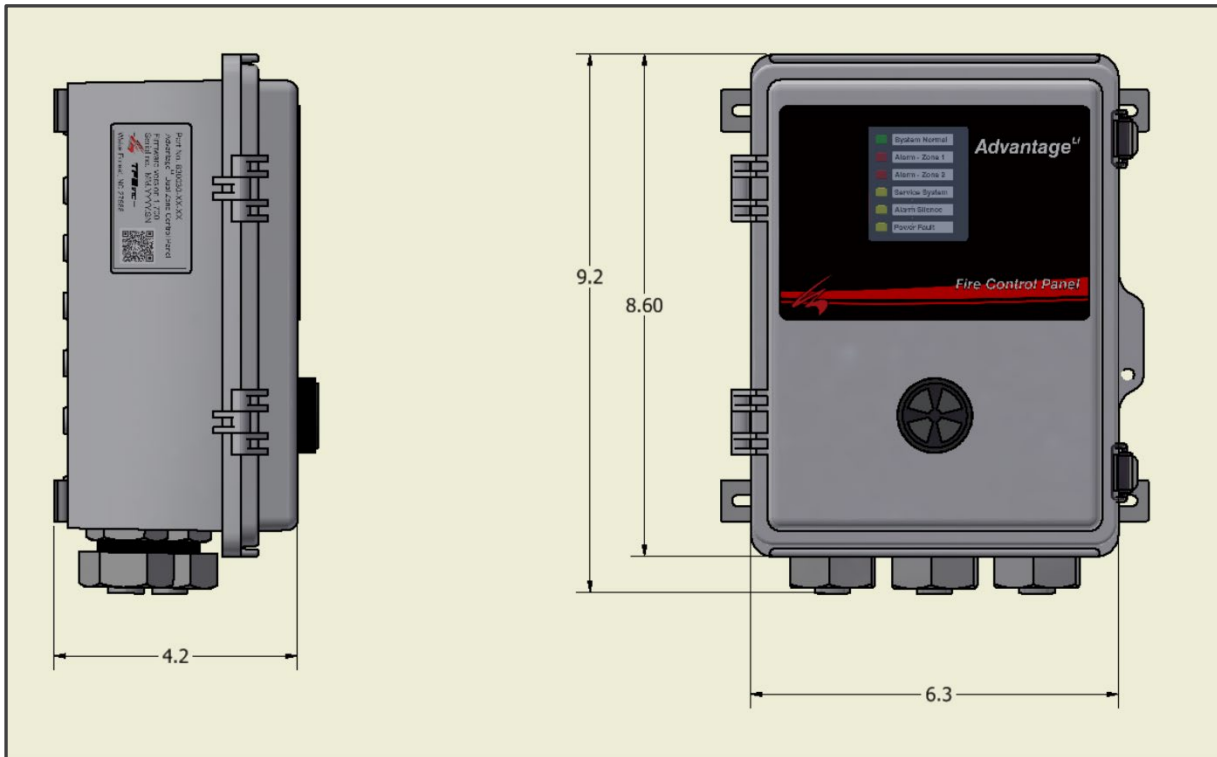

Electrical Specifications

Supervised Circuits		Visual Indicators	
Detection (initiating circuits)	Qty (2) Class B	System Normal	Green LED (flashing)
Manual Pull Station	Qty (1) Class B	Fire Zone 1 & Zone 2	Red LED (flashing)
Agent Cylinder Pressure Switch	Qty (1)	Service System	Yellow LED (flashing)
Actuation Circuits	Qty (2)	Battery Fault	Yellow LED (flashing)
Primary & Secondary Battery Circuits	Qty (2)	Alarm Silence	Yellow LED (flashing)
Local Audible Annunciator	Qty (1)		
Front Panel Controls		Batteries	
Push to Test button		Chemistry	Lithium Thionyl Chloride
Alarm Silence		DOT Listing	DOT Verification of Compliance Report Number 3541324BAT-001 tested to UN Manual of Tests and Criteria, Part III, sub-section 38.3
System Reset			
Remote Programming Port			

Field Wiring Specifications

Detection Circuits		Manual Release Circuit	
Maximum length: 400' each circuit		Maximum length: 400' each circuit	
Maximum linear resistance: 50 ohms		Maximum linear resistance: 50 ohms	
Conductor cross section: 16-18 AWG		Conductor cross section: 16-18 AWG	
Gold terminal contacts only		Gold terminal contacts only	
IP67 sealed connectors		IP67 sealed connectors	
Terminating End of Line: 470k ohms		Terminating End of Line: 470k ohms	
Actuation Circuit		Pressure Switch Circuit	
Maximum length: 100' each circuit		Maximum length: 400'	
Maximum linear resistance: 1 ohm		Maximum linear resistance: 50 ohms	
Conductor cross section: 16-18 AWG		Conductor cross section: 16-18 AWG	
Gold terminal contacts only		Gold terminal contacts only	
IP67 sealed connectors		IP67 sealed connectors	
Auxiliary Contacts		Pluggable Terminal Strips	
Maximum Voltage	30 vdc	Conductor Cross Section	14-24 AWG
Current Rating	Normally Open = 1 amp Normally Closed = ½ amp	Wire Terminal Torque	5 in-lb. (0.5 – 0.6 nm)
		Wire Strip Length	0.275" (7 mm)

Mechanical Specifications

Enclosure Dimensions	6.3" W x 8.6" L x 3.9" D (152mm x 221mm x 107 mm)	System Normal	Green LED (flashing)
Weight	1.90 lbs. / (0.89 kg)	Fire Zone 1 & Zone 2	Red LED (flashing)
		Service System - Trouble	Yellow LED (flashing)
		Battery Fault	Yellow LED (flashing)
Primary & Secondary Battery Circuits	Qty (2)	Alarm Silence	Yellow LED (flashing)
Local Audible Annunciator	Qty (1)		

Environmental Specifications

Module Electronics	-40°F to 185°F -40°C to +85°C		
Lithium Thionyl Chloride Batteries	-40°F to 185°F -40°C to +85°C* Battery life may be affected at temperatures above +120°F (49°C)	Enclosure Listed Ratings	UL 508 NEMA Type 4X IP67 UL 94V-0

As part of an ongoing program of product evaluation and improvement, Total Fire Systems, Inc. reserves the right to change its literature, product, and service offerings at any time without notice.

Rev. Jan 2025